

## Garden Planter Assembly

Standing Planter with Shelf v 1.2

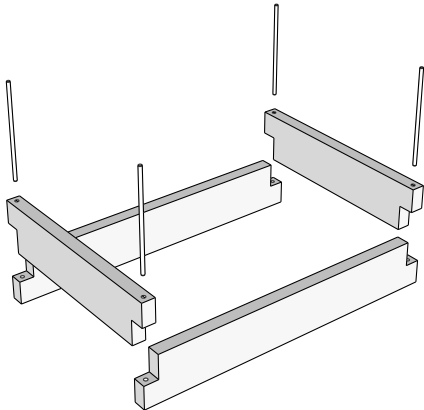

### Step 1

On a flat surface, position the side boards so the notched ends overlap, forming a box. Insert the corner pins to lock the boards together.

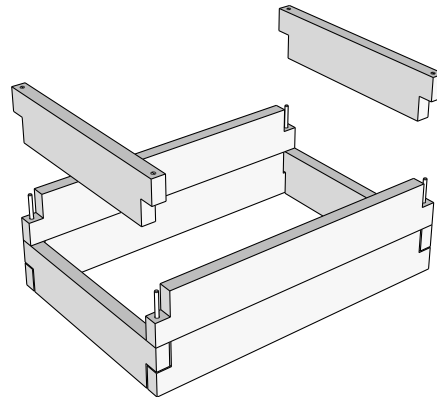

### Step 2

Stack the remaining side boards on top of the first to form walls 1-3 layers (5.5"-16.5") deep, depending on planter model.

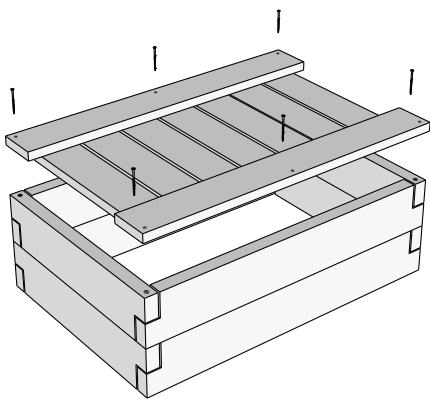

### Step 3

Place the pre-assembled planter bottom on top of the side boards. Attach with the included screws.

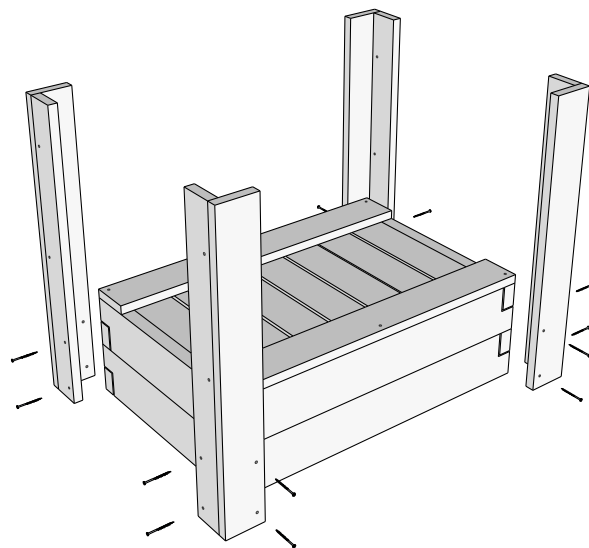

### Step 4

Attach the legs to the side boards, as shown, with the support block screw holes on opposite sides and the legs flush at the bottom.



# Naturalyards

AT HOME WITH NATURE

## Garden Planter Assembly

Standing Planter with Shelf v 1.2

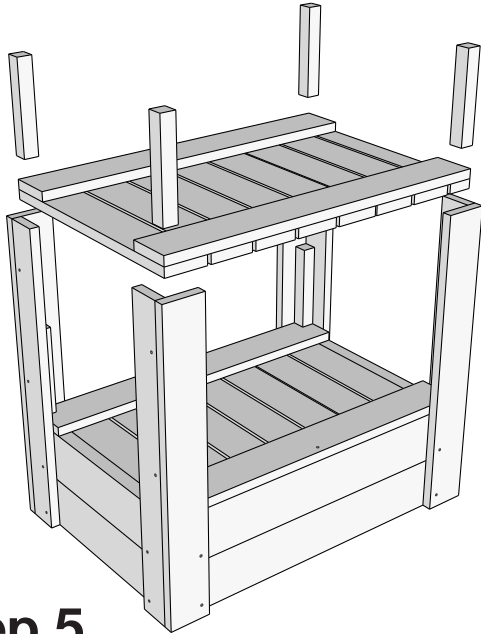

### Step 5

Position support blocks at the inside corners of each leg, above and below the shelf, with the shelf in the middle.

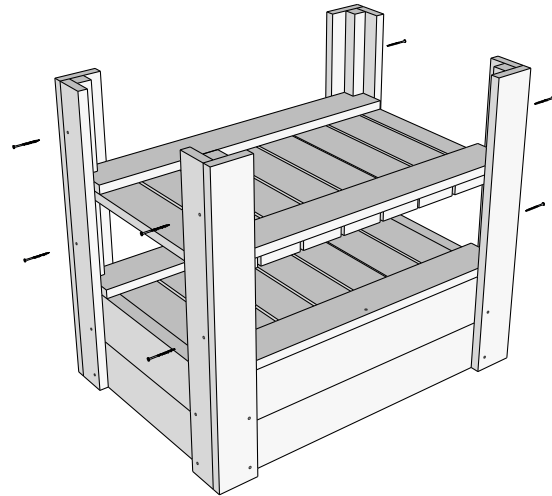

### Step 6

Screw the support blocks to the legs, holding the blocks firmly against the inside corners and shelf.

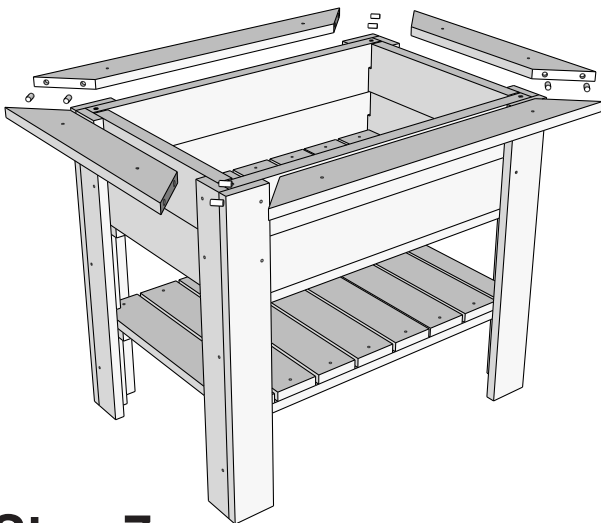

### Step 7

Turn the planter right-side-up. Assemble the top rail by inserting dowels into the ends of each board and fitting the pieces together.

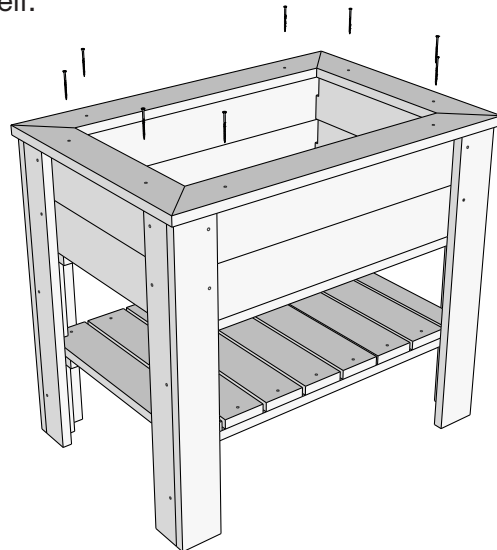

### Final Step

Center the top rail in both directions and screw it to the top of the planter. Add an optional liner. Fill with soil and you are ready to plant!