

Step 1

Level the ground and position side boards so the notched ends overlap. Insert corner pins to lock the boards together. **Do not** stake pins into ground.

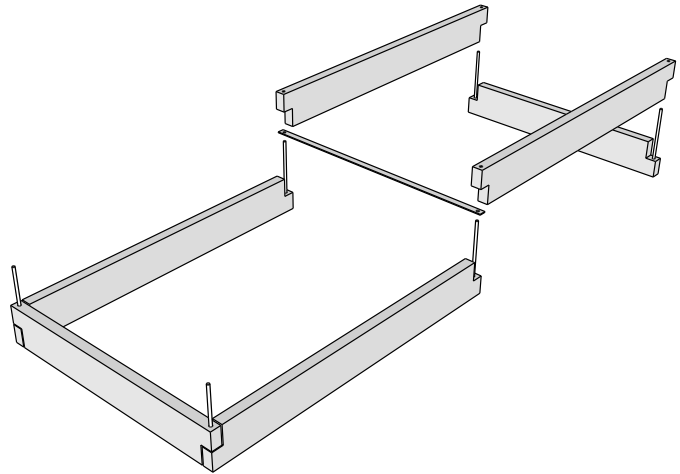

Step 2

Long beds are built in sections that include crossbar supports to prevent the sides from bowing. Place crossbars over pins between board sections.

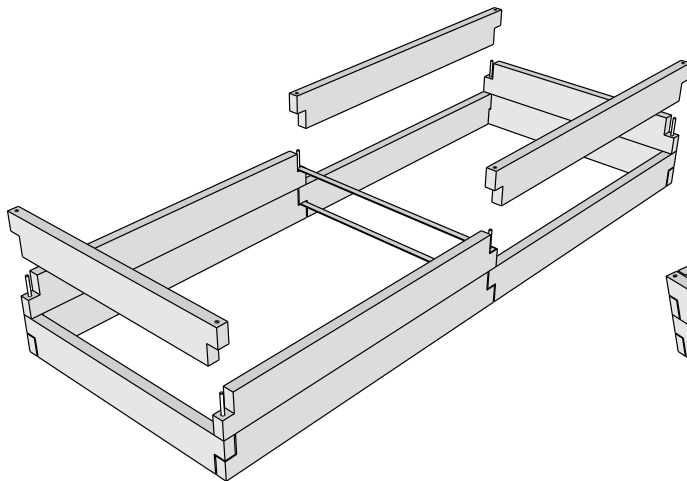

Step 3

Stack the remaining boards to build the height of the planter. Position crossbars at the top and bottom layers, with a third crossbar in-between for beds 27" and deeper.

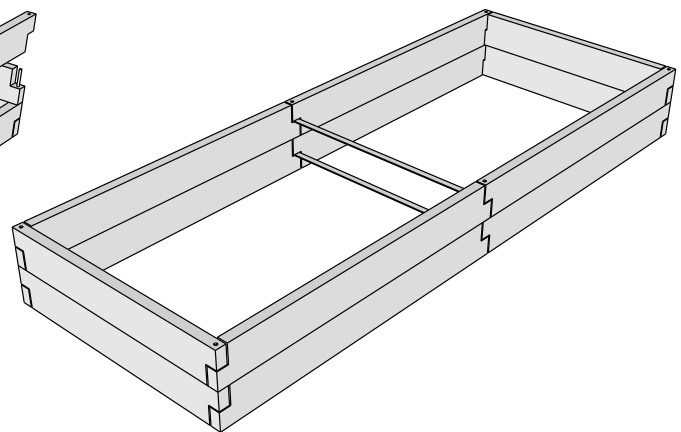

Final Tip

Loosen the ground inside of the bed and add an optional 1-3 inches of gravel to improve drainage. Fill with soil to about an inch below the top and you are ready to plant!